

## COMMERCIAL VERTICAL MIXER **EMP-V**

### Features

- ◆ Available in 20 Qt capacities
- ◆ Durable motor designed for heavy duty mixing applications and three speeds.
- ◆ The motor is totally enclosed, permanently lubricated, and thermally protected for years of reliable use.
- ◆ Fully sealed, heat treated carbon steel gears offer smooth, quiet operation.
- ◆ Lever-action bowl lift is easy to operate and self locking in top position.
- ◆ Spiral dough hook, flat batter beater and wire whip are all standard.
- ◆ Bowl guard with magnetic lock prevents the unit from running if guard is open.
- ◆ Overload Switch on all mixers prevents motor burn-out.
- ◆ All switches are moisture resistant for clean operation.



EMP-V20 Shown

### Reliability is in the Mix!

These all-purpose mixers use a planetary mixing action that consistently blends, mixes and aerates all ingredients with exceptional results. The heat treated carbon steel gears delivers efficient and consistent energy at three speeds.

Each mixer comes standard with a stainless steel bowl, flat beater, spiral dough hook, and wire whip. The stainless steel wire front bowl guard opens easily for adding ingredients. The magnetic bowl guard lock prevents the mixer from running if guard is opened or the bowl is lowered. All switches are moisture resistant, and each unit come with an overload switch which protects the motor.



# Technical Data

## COMMERCIAL VERTICAL MIXER EMP-V

Model	Dimensions			Bowl Capacity	Speed	Weight	Power (120v/60Hz/1Ph)	
	Width (A)	Depth (B)	Height (C)				HP	Amps
	in	in	in	Qt.	RPM	lbs.		
EMP-V20	23.6"	27.5"	30.7"	20	108 (I) 195 (II) 355 (III)	227	1.5	12

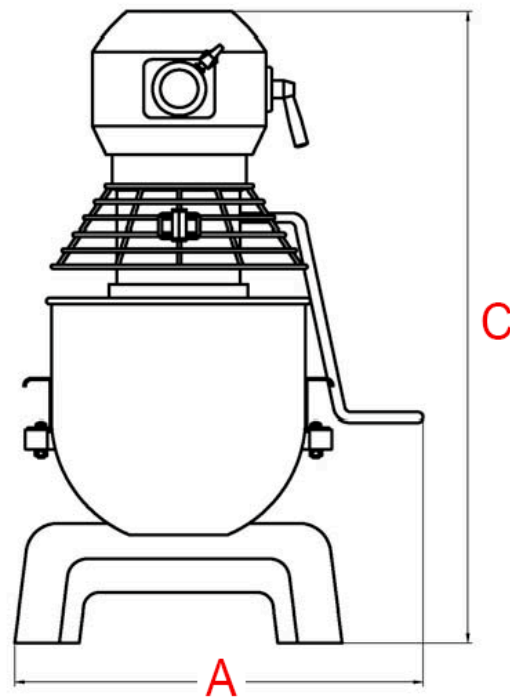
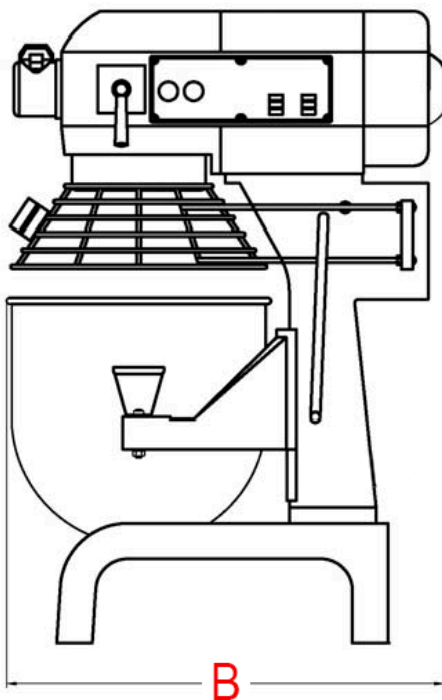

### LIMITED WARRANTY

This product is warranted to the original purchaser to be free from material and workmanship defects. This warranty extends for a period of one (1) year from the date of purchase on parts and labor and 90 days on electrical components. For additional information or if you have any questions, please do not hesitate to contact us toll free at 1-800-878-4070.

*Please note, specifications are subject to change without notice as we continually work to improve our equipment.*



1C Enterprise Place, Hicksville, NY 11801-5356 ♦ Ph: (516) 681-1500 ♦ Fx: (516) 681-1510  
1-800-878-4070 ♦ www.empirebake.com ♦ info@empirebake.com