

DOUBLE RACK OVEN **LFR-2**

Features

- ◆ Heavy Duty Mechanical Rack Lifting Device.
- ◆ Lifters available for a variety of rack styles
- ◆ Recessed Digital Control Panel
- ◆ Self Contained, Hi Volume Steam Generating System
- ◆ Vented, Double-Pane Viewing Window
- ◆ 304 Stainless Steel Panels
- ◆ Smooth Profile and Enclosed Hinges for Greater Sanitation.
- ◆ Front Mounted Burner/Service Access
- ◆ Long Life Halogen Lights
- ◆ Available in Gas,Oil Fired or Electric



Options & Accessories

- ◆ *ORION* Digital Control Panel with storage for up to 99 recipes
- ◆ LCD Touch Screen Control Panel with Advanced Programming Capabilities and Variable Speed Controls
- ◆ Sturdy High-Temperature Baking Racks Available

Rack Oven Baking at its BEST!!

Incorporating all the latest design principles for great baking, safety, economy and long lasting reliability the **LFR-2 Double Rack Oven** is ideal for high volume bakeries, supermarkets, wholesale operations, kitchens or restaurants. It's perfectly suited for bagels, breads, the most delicate cakes and pastries.

The **LFR-2 Double Rack Oven's** digital controls make it easy to operate, and the heavy duty lifting system is totally mechanical to ensure years of trouble free operation. Gentle airflow and energy efficient design provide you with the highest quality baking and years of low cost operation. Empire's LFR rack ovens meet the highest standards in quality, reliability, consistency and durability for the bakery and food service industries.



Technical Data

DOUBLE RACK OVEN LFR-2

Model	Overall Dimensions (in inches)					Weight lbs	Electrical* (220V/3Ph/60Hz)	BTU	Water		Gas	Exhaust	
	Width (A)	Depth (B)	Depth w/ Hood (C)	Height (D)	Height w/ Fan (E)				Supply in	Drain in		Steam in	Burner in
LFR-2G	85.5"	57.9"	69.7"	90.6"	105.5"	3750	10 Amp	280,000	1/2"	1"	3/4" NPT	10"	8"
LFR-2E	85.5"	57.9"	69.7"	90.6"	105.5"	3750	169.8 Amp	--	1/2"	1"	--	10"	--

*Gas/Oil Burners require 110V and will need a separate line if 220V line is not supplied with neutral and ground.



FRONT VIEW

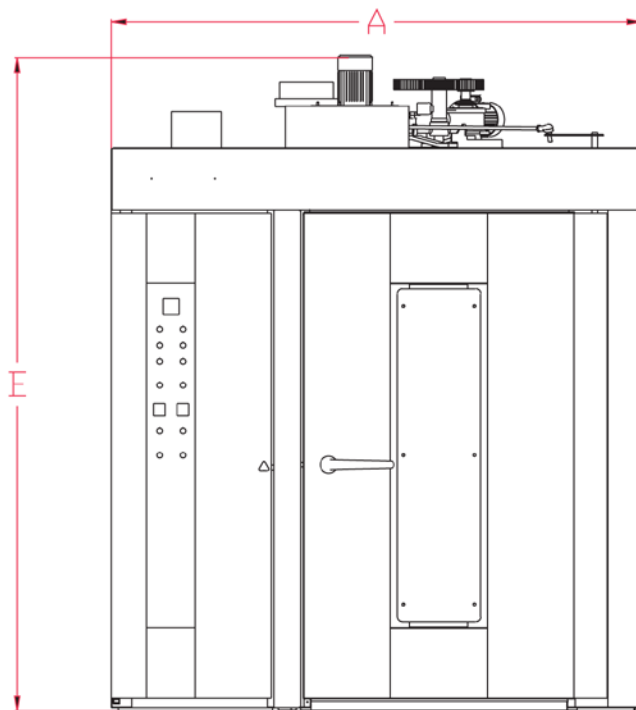

SIDE VIEW

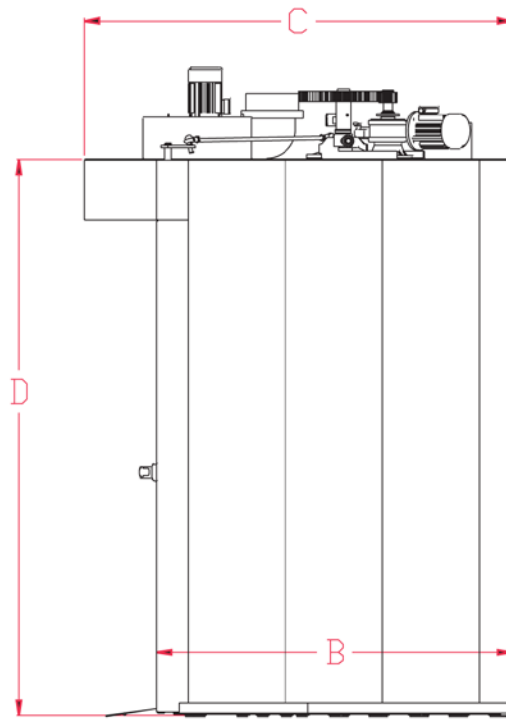

LIMITED WARRANTY

This product is warranted to the original purchaser to be free from material and workmanship defects. This warranty extends for a period of one (1) year from the date of purchase on parts and labor and 90 days on electrical components. For additional information or if you have any questions, please do not hesitate to contact us toll free at 1-800-878-4070.

Please note, specifications are subject to change without notice as we continually work to improve our equipment.



1C Enterprise Place, Hicksville, NY 11801-5356 ♦ Ph: (516) 681-1500 ♦ Fx: (516) 681-1510
 1-800-878-4070 ♦ www.empirebake.com ♦ info@empirebake.com