

## COOKIE DEPOSITOR **MAXIDROP EASY**

### Features

- ◆ User-friendly 7" touch screen control panel
- ◆ Interchangeable heads; your choice of either hard dough or fluid pump heads
- ◆ 200-Recipe memory capacity
- ◆ A wide range of molds and nozzles
- ◆ Electronically adjustable dosing speed
- ◆ Electronic adjustment of table height position
- ◆ Adjustable anti-dropping device for cleaner deposits
- ◆ Automatic starting controls
- ◆ Easy to clean quickly and thoroughly
- ◆ Output capacity ranging from 4-7 trays/min (depending on cookie size and inclusions)
- ◆ Panel USB port for saving and restoring recipes (on request)
- ◆ Voltage: 220V/60Hz/1ph/10A

### Options & Accessories

- ◆ Wide range of nozzles, moulds and dies available
- ◆ Fluid pump head for soft dough and batters
- ◆ Big American Head - for larger style cookie favorites like chocolate chip, oatmeal, Snickerdoodles and more!



### Maximize Your Cookie Production

The **MAXIDROP EASY Cookie Depositor** offers the maximum in terms of performance and sturdiness, accompanied by high flexibility. Suitable for medium to large spaces that require varied and intensive production. With an intuitive, easy-to-use touch screen control panel and a 200-recipe memory capacity the **MAXIDROP EASY** is capable of producing a large variety of consistent, high-quality cookies per hour and is perfect for the production of quality and consistent macarons. With a large variety of nozzles and moulds available, the **MAXIDROP EASY Cookie Depositor** allows production in the most varied shapes and sizes.

# Technical Data

## COOKIE DEPOSITOR MAXIDROP EASY

### SPECIFICATIONS

Hopper Capacity (Liters)	43
Weight (Lbs.)	639
Power	220V / 1Ph / 10A

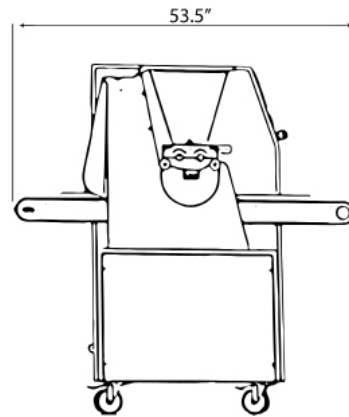
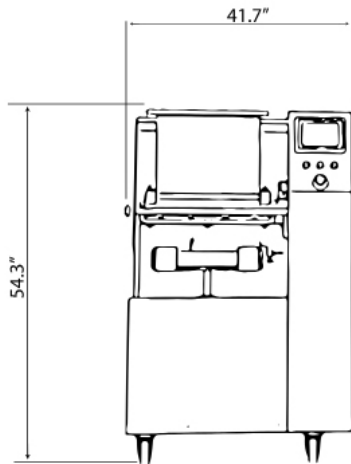

The Touch Screen Control Panel is intuitive, functional & very easy to use.



In addition to the standard hard dough dosing head, (left), the **MAXIDROP EASY** can also be equipped with an optional pump head for soft doughs and batters, (below).

A wide array of nozzles and moulds allows for an almost unlimited range of shapes and sizes.



### LIMITED WARRANTY

This product is warranted to the original purchaser to be free from material and workmanship defects. This warranty extends for a period of one (1) year from the date of purchase on parts and labor and 90 days on electrical components. For additional information or if you have any questions, please do not hesitate to contact us toll free at 1-800-878-4070.

Please note, specifications are subject to change without notice as we continually work to improve our equipment.



1C Enterprise Place, Hicksville, NY 11801-5356 ♦ Ph: (516) 681-1500 ♦ Fx: (516) 681-1510  
1-800-878-4070 ♦ www.empirebake.com ♦ info@empirebake.com