

HI-CAPACITY REMOVABLE BOWL MIXER **ESV**

Features

- ◆ Consistent Production of up to 660 lbs of Dough per Mix
- ◆ Heavy Duty Motor (Up to 30HP)
- ◆ Power Inverter for Variable Speed Control and Long Motor Life
- ◆ 4.3" LCD Touch Screen Control Panel with 6 Step Mixing Process
- ◆ Coordinated Spiral and Bowl Drive
- ◆ Stainless Steel Bowl, Spiral Breaker Bar and Guard
- ◆ Reversible Bowl Rotation
- ◆ Heavy Duty Frame and Durable Construction
- ◆ Hydraulic Head Lift and Bowl-Docking Mechanism Insures Positive Bowl Locking and Smooth Action of Automatic Head Lift and Bowl Release

Options

- ◆ Interchangeable Hub & Tool System
- ◆ Standard Bowl Scraper (Fixed)
- ◆ Temperature Probe with Thermostat
- ◆ Additional Bowls available
- ◆ Hydraulic and Chain Drive Bowl Lifts Available



Industrial Strength, Capacity and Versatility

Even stronger than the original! Empire's new and improved **ESV Removable Bowl Spiral Mixer** features advanced engineering and rugged construction. The variable speed 30HP motor is strong enough to handle any dough, and the optional interchangeable tool system means the **ESV's** versatility is unmatched!

The programmable touch screen control panel gives you full control over the entire mixing process. Coordinated spiral and bowl rotation provides intelligent ingredient blending, dough development and an overall better end product. Removable bowl design allows one mixer to run several production lines or to utilize bowls for long floor time dough. User friendly controls and heavy duty components throughout assure simple operation and reliable service.



Technical Data

HI-CAPACITY REMOVABLE BOWL MIXER **ESV**

All Models 220V 3-Phase 60 Cycle (Other voltages available)

Model	Capacity			Dimensions					Weight	Power		
	Bread Dough ¹	Bagel Dough ²	Bowl	Width (A)	Depth (B)	Height (closed) (C)	Height (open) (D)	Bowl Height (E)		Total Kw	Spiral HP	Total Amps
	flour / dough	flour / dough	qt	in.	in.	in.	in.	in.	lbs.			
EMP-160-ESV	213 / 353	174 / 264	220	55.5	78.7	59.8	77.6	34.3	3080	17.2	20	55.7
EMP-200-ESV	275 / 440	217 / 330	240	55.5	78.7	59.8	77.6	35.4	3090	17.2	20	55.7
EMP-300-ESV	413 / 660	326 / 495	380	61.4	89.0	62.2	85.4	37.4	4125	26.0	30	80.5

¹ Bread Dough capacities calculated at approximately 60% hydration. Actual capacities will vary based on specific hydration and consistency.

² Bagel Dough capacities calculated at approximately 52% hydration. Mixers used for bagel and other low hydration doughs are rated at low speed only. Operation at high speed will void the warranty and risk damage to the machine.

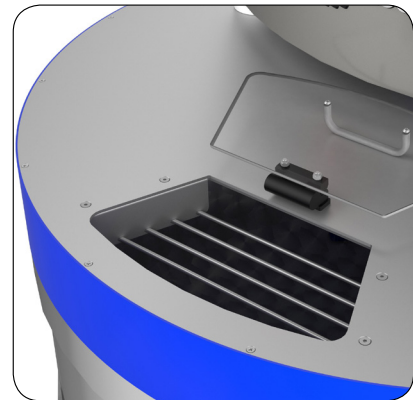
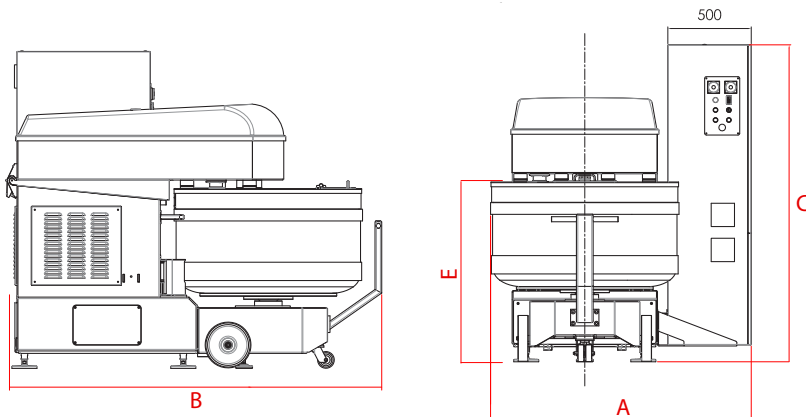

Access Hatch on Cover (Standard)

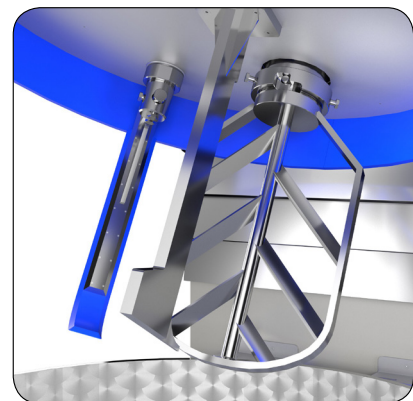
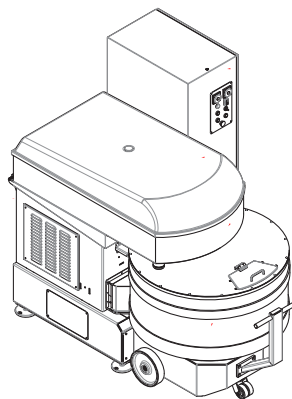
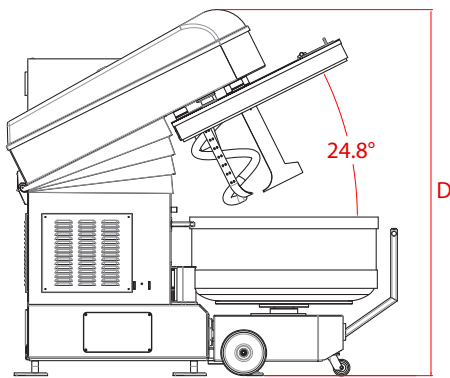

Interchangeable Tools with Hub (Optional)

LIMITED WARRANTY

This product is warranted to the original purchaser to be free from material and workmanship defects. This warranty extends for a period of one (1) year from the date of purchase on parts and labor and 90 days on electrical components. For additional information or if you have any questions, please do not hesitate to contact us toll free at 1-800-878-4070.

Please note, specifications are subject to change without notice as we continually work to improve our equipment.



1C Enterprise Place, Hicksville, NY 11801-5356 ♦ Ph: (516) 681-1500 ♦ Fx: (516) 681-1510
1-800-878-4070 ♦ www.empirebake.com ♦ info@empirebake.com